

UTC1117

LINEAR INTEGRATED CIRCUIT

1A LOW DROPOUT POSITIVE VOLTAGE REGULATOR

DESCRIPTION

The UTC1117 is a 1A low-dropout positive voltage regulator. It is available in fixed and adjustable output voltage versions. Over-current and thermal protection are integrated onto the chip. Output current will decrease while it reaches the pre-set current or temperature limit. The dropout voltage is specified at 1.2V Maximum at full rated output current. UTC1117 Series provides excellent regulation over line, load and temperature variations.

FEATURES

- * Low dropout voltage1.2V at 1A
- * Adjustable or fixed voltages
- * Typical line regulation 0.2%
- * Typical load regulation 0.15%
- * Adjust pin current less than 90mA
- * Over-current protection
- * Thermal protection

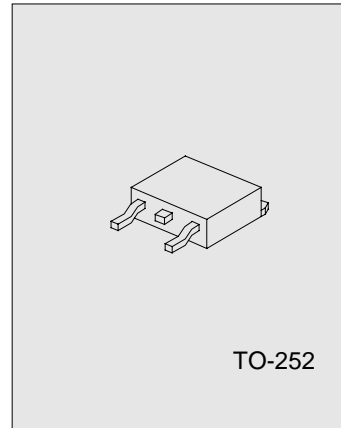

APPLICATIONS

- * High Efficiency Linear Regulators
- * 5V to 3.3V Voltage Converter
- * Battery Charger
- * Post Regulators for Switching supplies

BLOCK DIAGRAM

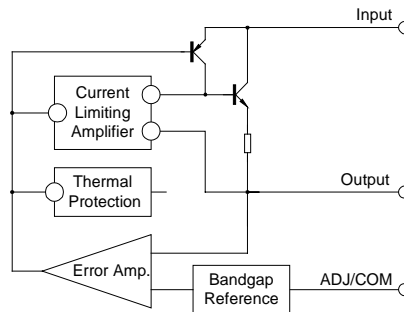

PIN CONFIGURATION

TO-252 Top View

SOT-223 Top View

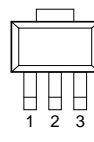
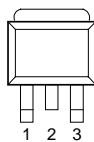

1: GND/ADJ
2: VOUT
3: VIN

1: GND/ADJ
2: VOUT
3: VIN

ABSOLUTE MAXIMUM RATINGS

Characteristic		Symbol	Value	Unit
Input Voltage		V _{IN}	15	V
Thermal Resistance (Junction to Case)	SOT-223	θ_{JC}	27*	°C/W
	TO-252		15	
Thermal Resistance (Junction to Ambient)	SOT-223	θ_{JA}	63*	
	TO-252		156	
Operating Junction Temperature Range		T _J	0 ~ 125	°C
Storage Temperature Range		T _{STG}	-65 ~ 150	
Lead Temperature (10 sec)		T _{LEAD}	260	

* Surface Mounted on 4 layers board based on JEDIC standard JC15.1

ELECTRICAL CHARACTERISTICS**UTC1117ACCT (Adjustable Version)**

Characteristic	Symbol	Test Condition	Min	Typ.	Max	Unit	
Reference voltage	V _{REF}	V _{IN} =5V, I _O =10mA	T _J =25°C	1.238	1.250	1.262	V
			Over Temp.	1.225	1.250	1.275	
Line regulation *	Reg _{LINE}	V _{IN} =4.75~7V, I _O =10mA	T _J =25°C			0.2	%
			T _J =25°C			0.3	
			Over Temp.			0.4	
Load regulation	Reg _{LOAD}	V _{IN} =5V, I _O =10mA~1A	T _J =25°C		0.05	0.3	%
			Over Temp.		0.2	0.4	
Dropout voltage	V _D	I _O =10mA~1A, $\Delta V_o = \pm 1\%$	Over Temp.		1.0	1.2	V
Current limit	I _S	V _{IN} =2.75~7V	Over Temp.	1.0			A
Temperature coefficient	T _C	V _{IN} =2.75~7V, I _O =10mA~1A		0.005			%/°C
Adjust pin current	I _{ADJ}	V _{IN} =2.75~7V, I _O =10mA~1A	T _J =25°C		55		μA
			Over Temp.			90	
Adjust pin current change	ΔI_{ADJ}	V _{IN} =2.75~7V, I _O =10mA~1A, Over Temp.		0.2	5		
Temperature stability	T _S	V _{IN} =2.75~7V, I _O =10mA~1A, Over Temp.		0.5			%
Minimum load current	I _O	V _{IN} =5V		5	10		mA
RMS output noise	V _N	T _J =25°C		0.003			%V _O
Ripple rejection ratio	R _A	V _{IN} =5V, I _O =1A, Over Temp.	60	72			dB

UTC1117ICCT (Fixed 3.3V Output Version)

Characteristic	Symbol	Test Condition	Min	Typ.	Max	Unit	
Output voltage	Vo	VIN=5V, Io=0A	TJ=25°C	3.270	3.3	3.330	V
			Over Temp.	3.234	3.3	3.330	
Line regulation *	RegLINE	VIN=4.75~7V, Io=0A	TJ=25°C			0.2	%
		VIN=4.75~15V, Io=0A	TJ=25°C			0.3	
Load regulation	RegLOAD		VIN=5V, Io=0A~1A	TJ=25°C		0.05	
		Over Temp.			0.2	0.4	
Dropout voltage	VD	Io=0A~1A, ΔVo=±1%, Over Temp.		1.0	1.2	V	
Current limit	Is	VIN=4.75~7V, Over Temp., Over Temp.	1.0			A	
Quiescent Current	Iq	VIN=5V, Io=0A~1A, Over Temp.		6	13	mA	
Temperature coefficient	Tc	VIN=4.75~7V, Io=0A~1A		0.005		%/°C	
Temperature stability	Ts	VIN=5V, Io=100mA~1A, Over Temp.		0.5		%	
RMS output noise	VN	TJ=25°C		0.003		%Vo	
Ripple rejection ratio	RA	VIN=5V, Io=1A, Over Temp.	60	72		dB	

* Line regulation test circuit

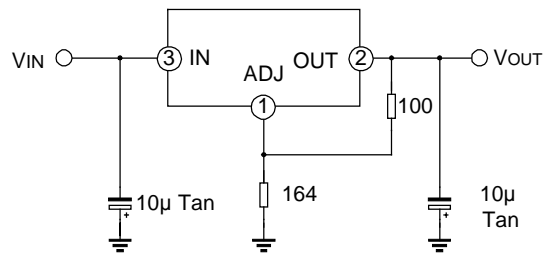

TYPICAL APPLICATION

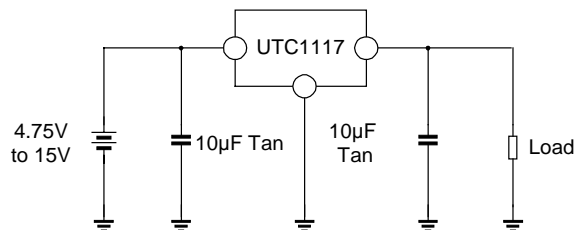

Input range depends on Vo.
Please refer to electrical characteristics

PERFORMANCE CHARACTERISTICS

1. Load regulation

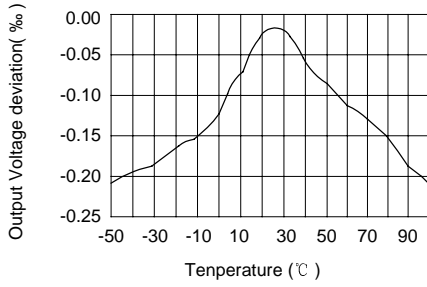

2. Short circuit current

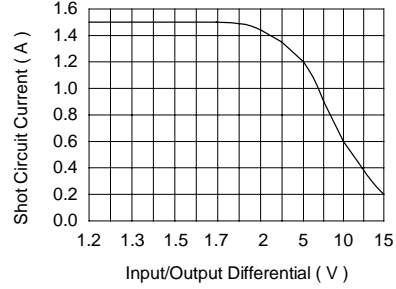

3. Temperature stability

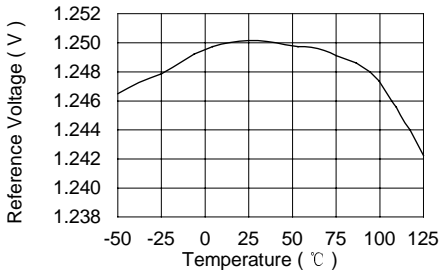

4. Dropout voltage

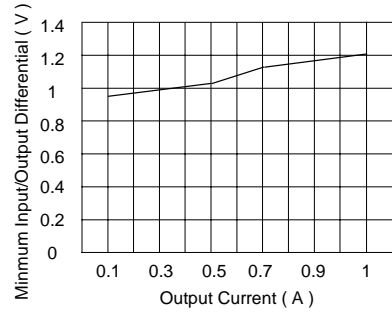

5. Adjust pin current

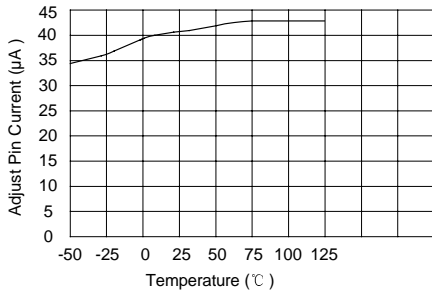

6. Minimum operating current

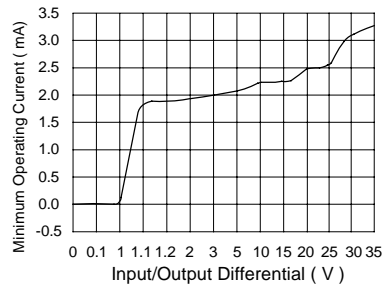

7. Load transient response

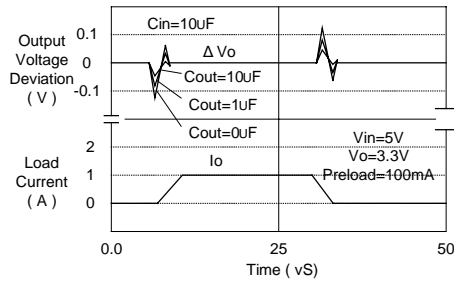

8. Line transient response

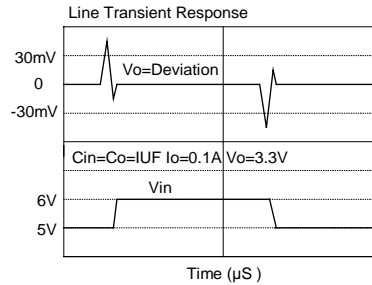

UTC1117

LINEAR INTEGRATED CIRCUIT

ORDERING INFORMATION

PART NUMBER	OUTPUT VOLTAGE	PACKAGE	MARKING	OPERATING TEMP. RANGE
UTC1117ACGT	1.30 to 12.0	SOT-223	ABE###	0°C to =125°C
UTC1117CCGT	3.3		ABF###	0°C to =125°C
UTC1117ACCT	1.30 to 12.0	TO-252 (DPAK)	UTC1117 ACCT #####	0°C to =125°C
UTC1117CCCT	3.3		UTC1117 CCCT #####	0°C to =125°C

represents the date code

APPLICATION DESCRIPTIONS

1. Output voltage adjustment

Like most regulators, the UTC1117 regulates the output by comparing the output voltage to an internally generated reference voltage. On the adjustable version, the V_{REF} is available externally as 1.25V between V_{OUT} and ADJ. The voltage ratio formed by R1 and R2 should be set to conduct 10mA (minimum output load). The output voltage is given by the following equation:

$$V_{OUT} = V_{REF} \left(1 + \frac{R2}{R1}\right) + I_{ADJ} \times R2$$

On fixed versions of UTC1117, the voltage divider is provided internally.

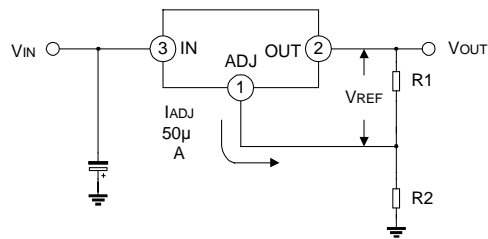

$$V_{OUT} = V_{REF} \left(1 + \frac{R2}{R1}\right) + I_{ADJ} \times R2$$

2. Thermal Protection

UTC1117 has thermal protection which limits junction temperature to 150°C. However, device functionality is only guaranteed to a maximum junction temperature of +125°C. The power dissipation and junction temperature for UTC1117 in DPAK package are given by

$$P_D = (V_{IN} - V_{OUT}) \times I_{OUT}$$

$$T_{JUNCTION} = T_{AMBIENT} + (P_D \times \theta_{JA})$$

Note: $T_{JUNCTION}$ must not exceed 125°C

3. Current Limit Protection

UTC1117 is protected against overload conditions. Current protection is triggered at typically 1.5A.

4. Stability and Load Regulation

UTC1117 requires a capacitor from V_{OUT} to GND to provide compensation feedback to the internal gain stage. This is to ensure stability at the output terminal. Typically, a $10 \mu F$ tantalum or $50 \mu F$ aluminum electrolytic is sufficient.

Note: It is important that the ESR for this capacitor does not exceed 0.5Ω .

The output capacitor does not have a theoretical upper limit and increase stability. $C_{OUT}=100 \mu F$ or more is typical for high current regulator design.

For the adjustable version, the best load regulation is accomplished when the top for the resistor divider ($R1$) is connected directly to the output pin of the UTC1117. When so connected, R_P is not multiplied by the divider ratio. For fixed output versions, the top of $R1$ is internally connected to the output and ground pin can be connected to low side of the load.

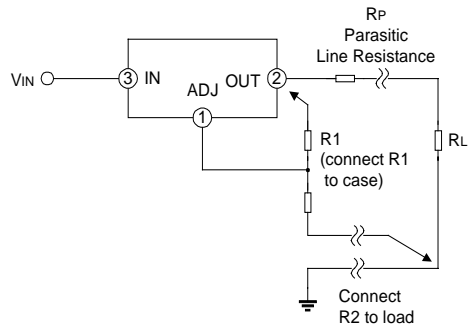

5. Thermal Consideration

The UTC1117 series contain thermal limiting circuitry designed to protect itself for over-temperature conditions, maximum junction temperature ratings must not be exceeded. As mention in thermal protection section, we need to consider all sources of thermal resistance between junction and ambient. It includes junction-to-case, case-to-heat-sink interface and heat sink thermal resistance itself.

Junction-to-case thermal resistance is specified from the IC junction to the bottom of the case directly below the die. Proper mounting is required to ensure the best possible thermal flow from this area of the package to the heat sink. The case of all devices in this series is electrically connected to the output. Therefore, if the case of the device must be electrically isolated, a thermally conductive spacer is recommended.

ADVANCED APPLICATIONS

Adjustable Output Voltage

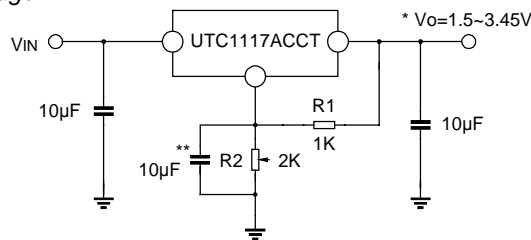

$$*V_o = V_{ref}(1 + R_2/R_1) + I_{adj} \times R_2$$

**Optional for improved ripple rejection

UTC1117

LINEAR INTEGRATED CIRCUIT

Paralleling Regulators

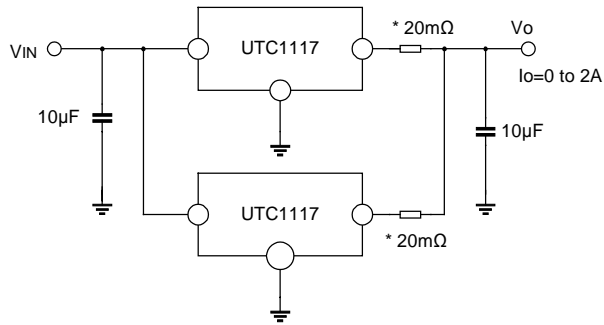

*20mΩ is ballast resistance

The inter-connection of #18 wire could act as ballast resistance.

Regulator with Reference

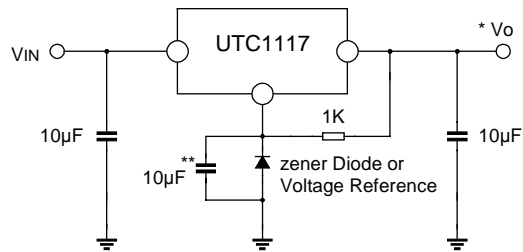

* $V_o = V_{ref} + V_z$ (V_z is breakdown voltage of zener Diode)

** Optional for improved ripple rejection

Regulator with Reverse Diode Protection

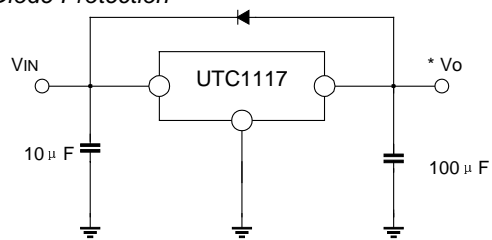

This datasheet has been downloaded from:

www.DatasheetCatalog.com

Datasheets for electronic components.