

LCD MOUDULE SPECIFICATION FOR APPROVAL	DATE	20/10/07
	VER.	1.0
Waveshare LCD1602	PAGE	3

CONTENTS

1.	FEATURES	4
2.	MECHANICAL SPEC	4
3.	ABSOLUTE MAXIMUM RATING	5
4.	ELECTRICAL CHARACTERISTICS	5
5.	ELECTRO-OPTICAL CHARACTERISTICS	6
6.	QC/QA PROCEDURE	7
7.	RELIABILITY	8
8.	BLOCK DIAGRAM	9
9.	POWER SUPPLY	9
10.	TIMIING DIAGRAM	10
11.	AC CHARACTERISTICS.....	11
12.	INSTRUCTION SET	12
13.	INITIALIZATION SEQUENCE	13
14.	FONT TABLE.....	14
15.	HANDLING PRECAUTION.....	15
16.	EXTERNAL DIMENSION	18
17.	INTERFACE	19

LCD MOUDULE SPECIFICATION FOR APPROVAL	DATE	20/10/07
	VER.	1.0
Waveshare LCD1602	PAGE	4

1. FEATURES

- Display construction..... 16 Characters * 2 Lines
- Display mode..... TN/STN
- Display type..... Positive Transflective
- Backlight..... LED(B/5.0V)
- Viewing direction..... 6 o' clock
- Operating temperature..... Indoor
- Driving voltage..... Single power
- Driving method..... 1/16 duty, 1/5 bias
- Type..... COB (Chip On Board)
- Number of data line..... 8-bit parallel
- Connector..... Pin

2. MECHANICAL DATA

ITEM		WIDTH	HEIGHT	THICKNESS	UNIT
Module size		80.0	36.0	14.0 (MAX)	mm
Viewing area		73.8	27.1	-	mm
character	Construction	5*7			dots
	Size	2.95	4.35	-	mm
	Pitch	3.65	5.05	-	mm
Dot	Size	0.55	0.5	-	mm
	Pitch	0.6	0.55	-	mm
Diameter of mounting hole		2.7			mm
Weight		About 50			g

LCD MODULE SPECIFICATION FOR APPROVAL	DATE	20/10/07
	VER.	1.0
Waveshare LCD1602	PAGE	5

3. ABSOLUTE MAXIMUM RATINGS

Characteristics	Symbol	Ratings
Operating Voltage	VDD	-0.3V to +7.0V
Driver Supply Voltage	V _{LCD}	VDD-12V to VDD+0.3V
Input Voltage Range	V _{IN}	-0.3V to VDD + 0.3V
Operating Temperature	T _A	0°C~+60 °C
Storage Temperature	T _{STO}	-55°C~+125 °C

4. ELECTRICAL CHARACTERISTICS

(T_A = 25 , VDD = 2.7 to 4.5V)

Characteristics	Symbol	Limit			Unit	Test Condition
		Min.	Typ.	Max.		
Operating Current	I _{CD}	-	0.2	0.4	mA	External clock (Note)
Input High Voltage	V _{IH1}	0.7VDD	-	VDD	V	Pins:(E, RS, R/W, DB7 - 0)
Input Low Voltage	V _{IL1}	-0.3	-	0.55	V	
Input High Voltage	V _{IH2}	0.7VDD	-	VDD	V	Pin OSC1
Input Low Voltage	V _{IL2}	-0.2	-	0.2VDD	V	
Input High Current	I _{IH}	-1.0	-	1.0	μA	Pins: (RS, R/W, DB7 - 0)
Input Low Current	I _{IL}	-5.0	-15	-30	μA	VDD = 3.0V
Output High Voltage (TTL)	V _{OH1}	0.75VDD	-	-	V	I _{OH} = - 0.1mA Pins: DB7 - 0
Output Low Voltage (TTL)	V _{OL1}	-	-	0.2VDD	V	I _{OL} = 0.1mA Pins: DB7 - 0
Output High Voltage (CMOS)	V _{OH2}	0.8VDD	-	-	V	I _{OH} = - 40μA, Pins: CL1, CL2, M, D
Output Low Voltage (CMOS)	V _{OL2}	-	-	0.2VDD	V	I _{OL} = 40μA, Pins: CL1, CL2, M, D
Driver ON Resistance (COM)	R _{COM}	-	-	20	KΩ	I _o = ±50μA, V _{LCD} = 4V Pins: COM16 - 1
Driver ON Resistance (SEG)	R _{SEG}	-	-	30	KΩ	I _o = ±50μA, V _{LCD} = 4V Pins: SEG40 - 1
LCD Voltage	V _{LCD}	3.0	-	11.0	V	VDD-V5, 1/4 bias or 1/5 bias

LCD MODULE SPECIFICATION FOR APPROVAL	DATE	20/10/07
	VER.	1.0
Waveshare LCD1602	PAGE	6

5. ELECTRO-OPTICAL CHARACTERISTICS

ITEM	SYMBOL	CONDITION	MIN.	TYP.	MAX.	UNIT	NOTE
Contrast ratio	K	$\phi=0$	1.4	4	-	-	1
Response time	Tr	$\phi=1$	-	130	-	ms	2
(rise) Response time	Tf	$\phi=2$		130	-	ms	2
(fall) Viewing angle	ϕ	$K \geq 1.4$	10 -- +30			deg.	3
	θ		-30 -- +30				

Note 1: Definition of Contrast Ratio "K"

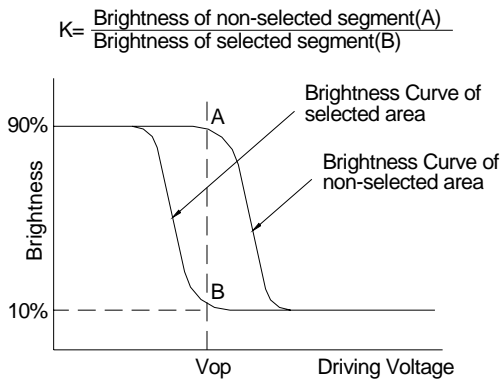

Note 2: Definition of Optical Response Time

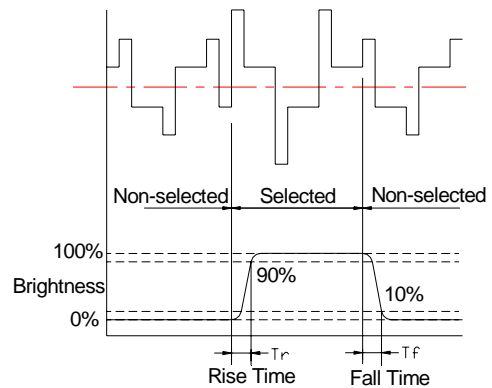

Note 3: Definition of Viewing Angle

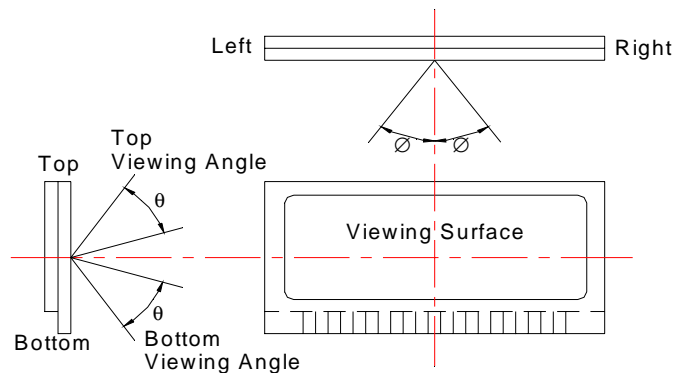

Please select either top or bottom viewing angle

LCD MOUDULE SPECIFICATION FOR APPROVAL	DATE	20/10/07
	VER.	1.0
Waveshare LCD1602	PAGE	7

6. QC/QA PROCEDURE

Parts QA Dept. LCD Mfg. Dept. LCM QA Dept.

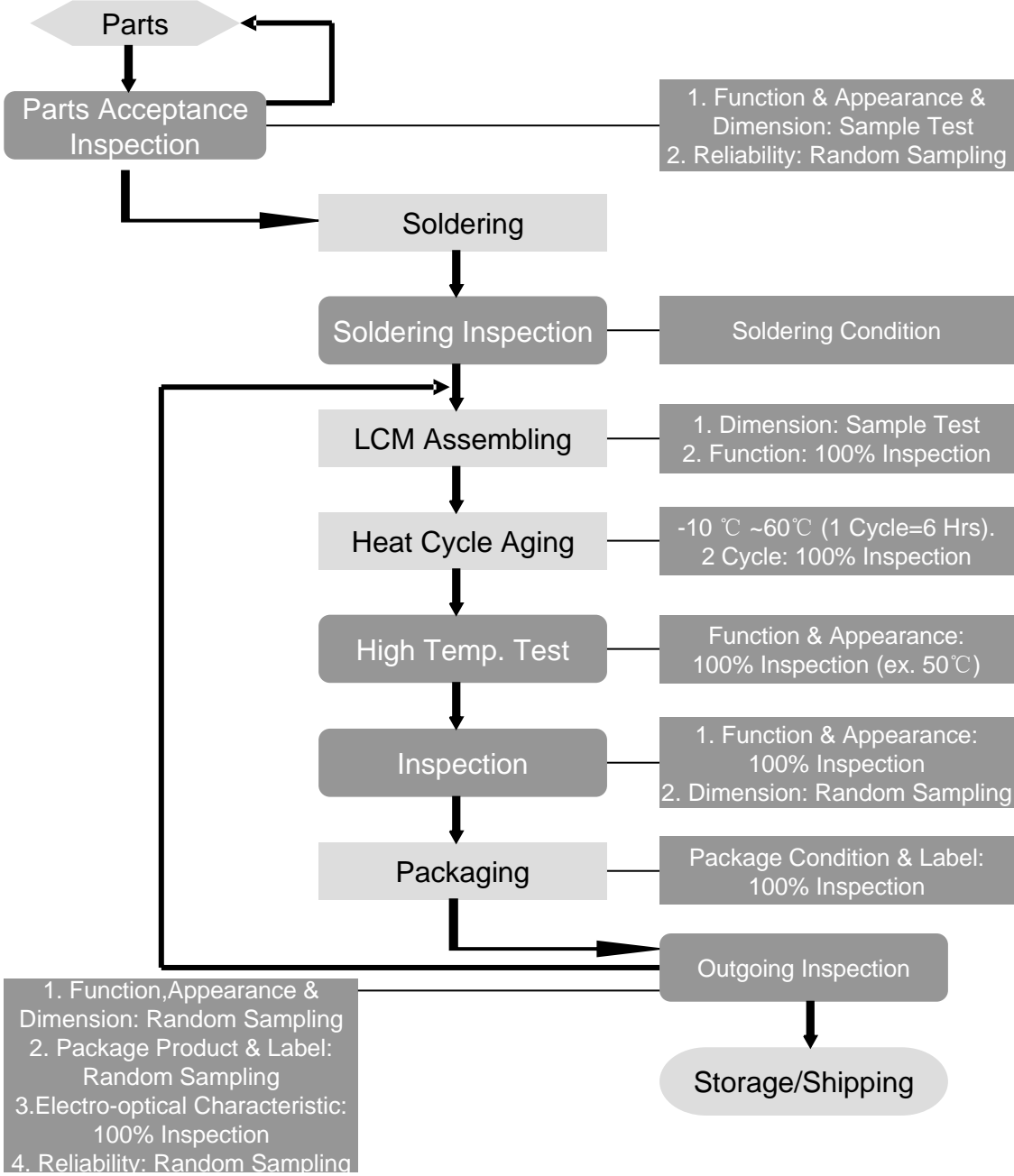

LCD MOUDULE SPECIFICATION FOR APPROVAL	DATE	20/10/07
	VER.	1.0
Waveshare LCD1602	PAGE	8

7. RELIABILITY

•Operating life time:

Longer than 50000 hours (at room temperature without direct irradiation of sunlight)

•Reliability Characteristics:

Item	Test	Criterion
High temp	60°C / 200 Hrs	◎Total current consumption should be below double of initial value ◎Contrast ratio should be within initial value±50% ◎No defect in cosmetic and operational function is allowable
Low temp.	-10°C / 200 Hrs	
High humidity	40°C * 90%RH / 200 Hrs	
Thermal shock	-10°C→25°C→60°C→25°C /5 Cycles (30min) (5min) (30min) (5min)	
Vibration	1. Operating time: Thirty minutes exposure in each direction (x, y, z) 2. Sweep Frequency (1min):10Hz→ 55Hz→10Hz 3. Amplitude: 0.75mm double amplitude	

LCD MODULE SPECIFICATION FOR APPROVAL	DATE	20/10/07
	VER.	1.0
Waveshare LCD1602	PAGE	9

8. BLOCK DIAGRAM

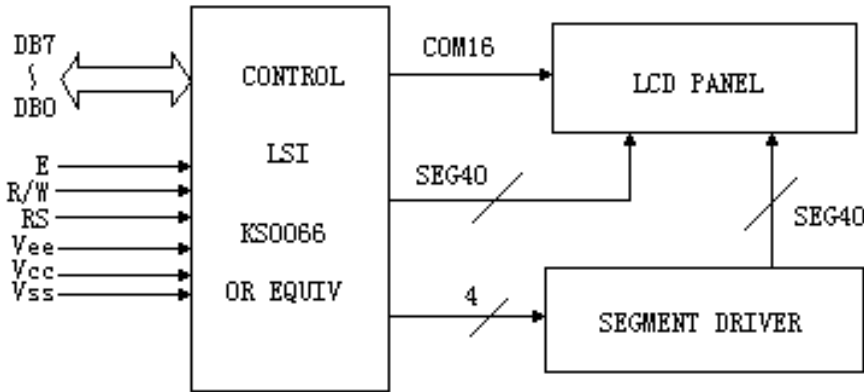

9. POWER SUPPLY

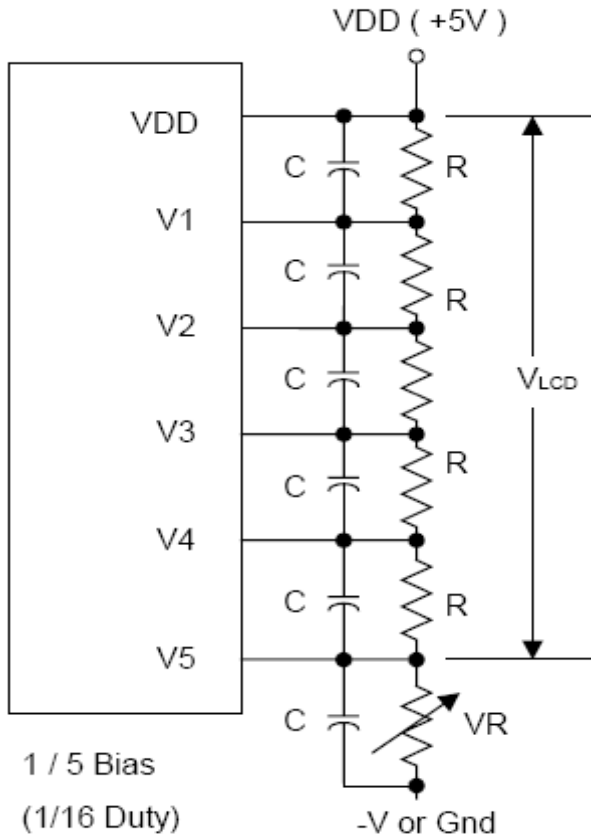

LCD MODULE SPECIFICATION FOR APPROVAL	DATE	20/10/07
	VER.	1.0
Waveshare LCD1602	PAGE	10

10. TIMING DIAGRAM

• **WRITE OPERATION**

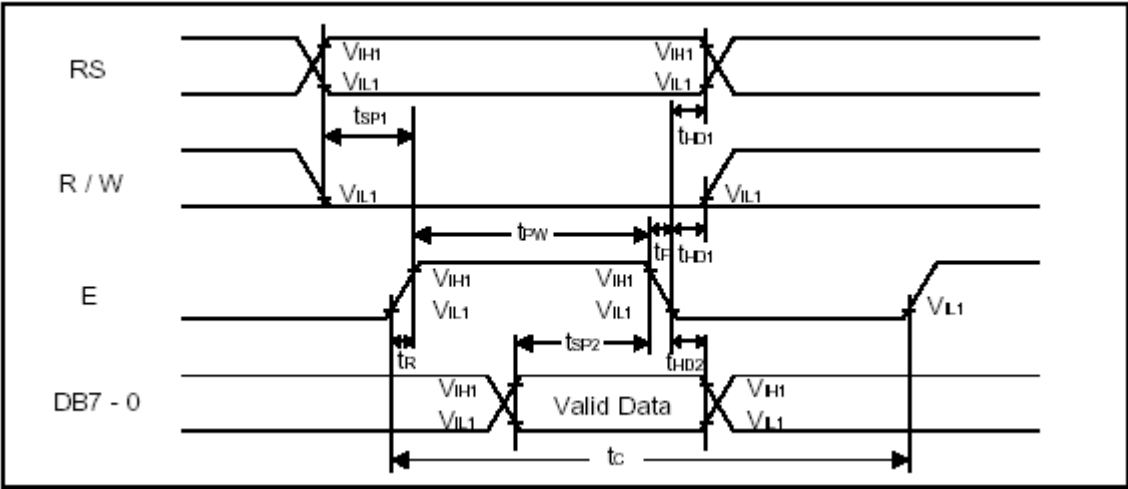

• **READ OPERATION**

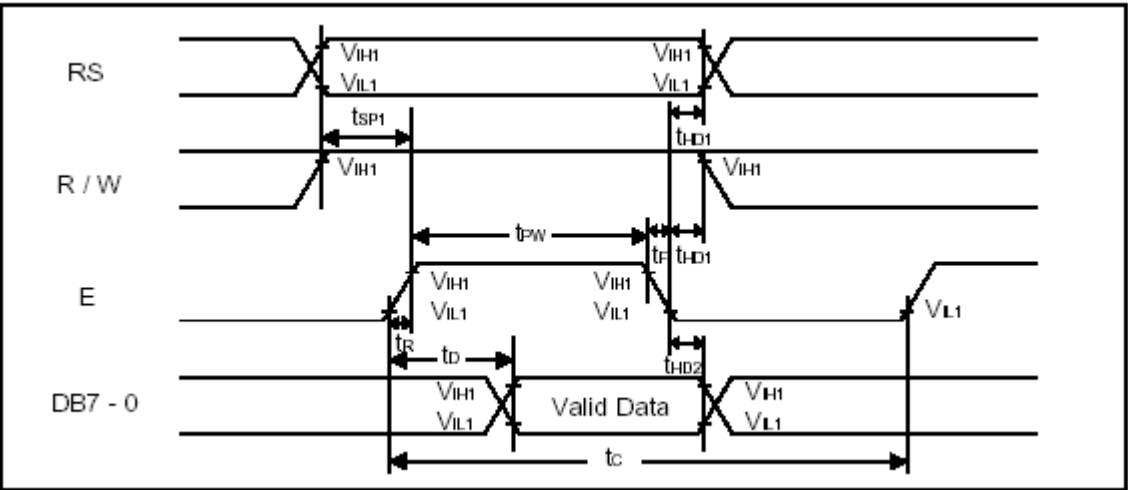

LCD MODULE SPECIFICATION FOR APPROVAL	DATE	20/10/07
	VER.	1.0
Waveshare LCD1602	PAGE	11

11. AC CHARACTERISTICS

• WRITE MODE

Characteristics	Symbol	Limit			Unit	Test Condition
		Min.	Typ.	Max.		
E Cycle Time	t _c	1000	-	-	ns	Pin E
E Pulse Width	t _{PW}	450	-	-	ns	Pin E
E Rise/Fall Time	t _r , t _f	-	-	25	ns	Pin E
Address Setup Time	t _{SP1}	60	-	-	ns	Pins: RS, R/W, E
Address Hold Time	t _{HD1}	20	-	-	ns	Pins: RS, R/W, E
Data Setup Time	t _{SP2}	195	-	-	ns	Pins: DB7 - 0
Data Hold Time	t _{HD2}	10	-	-	ns	Pins: DB7 - 0

• READ MODE

Characteristics	Symbol	Limit			Unit	Test Condition
		Min.	Typ.	Max.		
E Cycle Time	t _c	1000	-	-	ns	Pin E
E Pulse Width	t _w	450	-	-	ns	Pin E
E Rise/Fall Time	t _r , t _f	-	-	25	ns	Pin E
Address Setup Time	t _{SP1}	60	-	-	ns	Pins: RS, R/W, E
Address Hold Time	t _{HD1}	20	-	-	ns	Pins: RS, R/W, E
Data Output Delay Time	t _o	-	-	360	ns	Pins: DB7 - 0
Data hold time	t _{HD2}	5.0	-	-	ns	Pin DB7 - 0

LCD MODULE SPECIFICATION FOR APPROVAL	DATE	20/10/07
	VER.	1.0
Waveshare LCD1602	PAGE	12

12. INITIALIZATION SEQUENCE

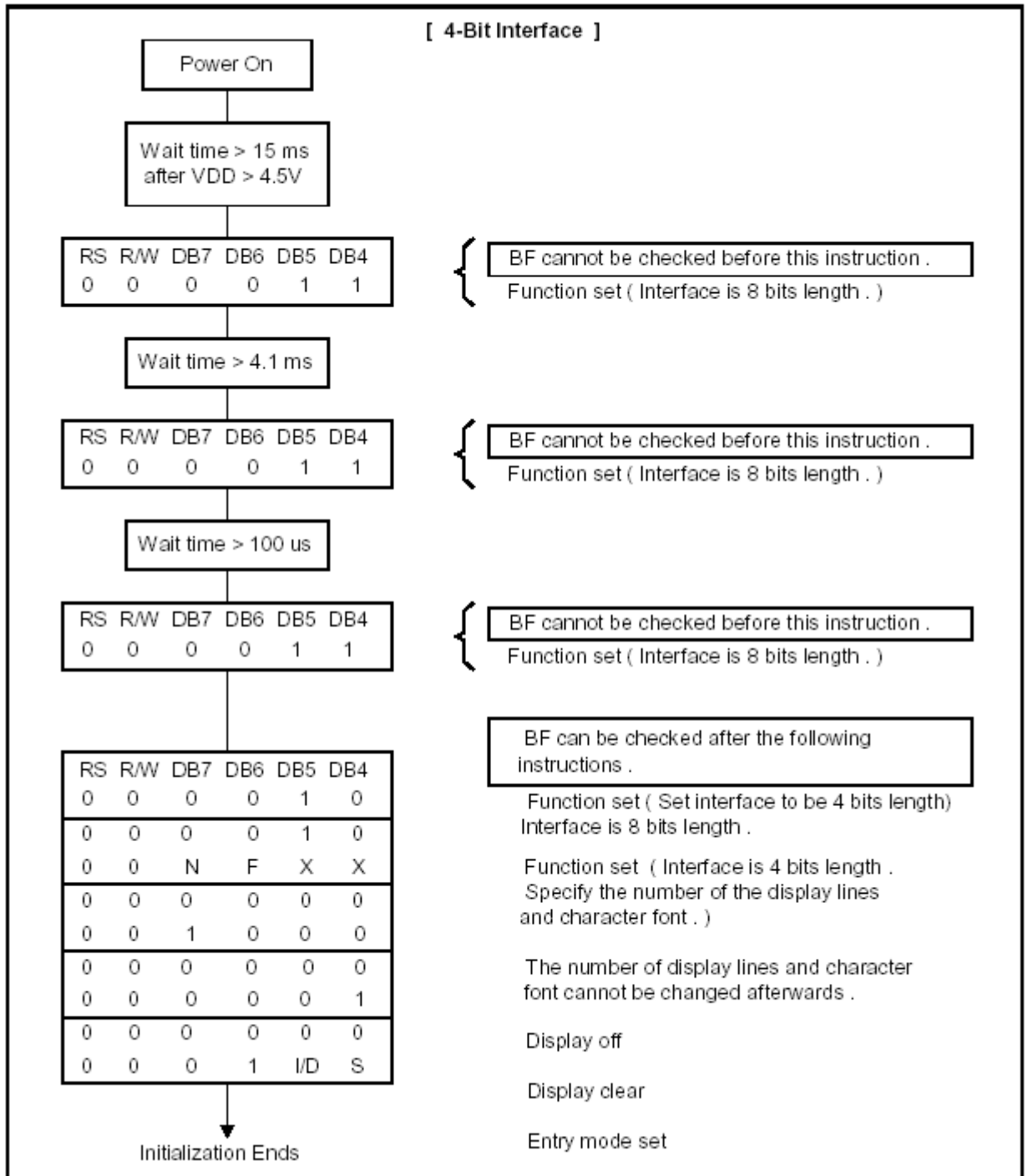

LCD MODULE SPECIFICATION FOR APPROVAL	DATE	20/10/07
	VER.	1.0
Waveshare LCD1602	PAGE	13

13. INSTRUCTION SET

COMMAND	COMMAND CODE										COMMAND CODE	E-CYCLE $f_{osc}=250\text{KHz}$	
	RS	R/W	DB7	DB6	DB5	DB4	DB3	DB2	DB1	DB0			
SCREEN CLEAR	0	0	0	0	0	0	0	0	0	1	Screen Clear, Set AC to 0 Cursor Reposition	1.64ms	
CURSOR RETURN	0	0	0	0	0	0	0	0	1	*	DDRAM AD=0, Return, Content Changeless	1.64ms	
INPUT SET	0	0	0	0	0	0	0	1	I/D	S	Set moving direction of cursor, Appoint if move	40us	
DISPLAY SWITCH	0	0	0	0	0	0	1	D	C	B	Set display on/off,cursor on/off, blink on/off	40us	
SHIFT	0	0	0	0	0	1	S/C	R/L	*	*	Remove cursor and whole display,DDRAM changeless	40us	
FUNCTION SET	0	0	0	0	1	DL	N	F	*	*	Set DL,display line,font	40us	
CGRAM AD SET	0	0	0	1	ACG							Set CGRAM AD, send receive data	40us
DDRAM AD SET	0	0	1	ADD							Set DDRAM AD, send receive data	40us	
BUSY/AD READ CT	0	1	BF	AC							Executing internal function, reading AD of CT	40us	
CGRAM/ DDRAM DATA WRITE	1	0	DATA WRITE							Write data from CGRAM or DDRAM	40us		
CGRAM/ DDRAM DATA READ	1	1	DATA READ							Read data from CGRAM or DDRAM	40us		
	I/D=1: Increment Mode; I/D=0: Decrement Mode S=1: Shift S/C=1: Display Shift; S/C=0: Cursor Shift R/L=1: Right Shift; R/L=0: Left Shift DL=1: 8D DL=0: 4D N=1: 2R N=0: 1R F=1: 5x10 Style; F=0: 5x7 Style BF=1: Execute Internal Function; BF=0: Command Received										DDRAM: Display data RAM CGRAM: Character Generator RAM ACG: CGRAM AD ADD: DDRAM AD & Cursor AD AC: Address counter for DDRAM & CGRAM	E-cycle changing with main frequency. Example: If fcp or $f_{osc}=270\text{KHz}$ 40us x 250/270 =37us	

LCD MOUDULE SPECIFICATION FOR APPROVAL	DATE	20/10/07
	VER.	1.0
Waveshare LCD1602	PAGE	14

14. FONT TABLE

b7- b3 -b0	b4	0000	0010	0011	0100	0101	0110	0111	1010	1011	1100	1101	1110	1111
0000	CG RAM (1)		0	a	P	`	P		-	9	E	α	P	
	(2)	!	1	A	Q	a	9	a	P	+	4	ä	q	
0010	(3)	"	2	B	R	b	r	7	4	W	×	ß	θ	
	(4)	#	3	C	S	c	s	1	0	T	E	ε	∞	
0100	(5)	\$	4	D	T	d	t	.	1	h	h	μ	Ω	
	(6)	%	5	E	U	e	u	.	+	1	1	ε	Ü	
0110	(7)	&	6	F	V	f	v	9	+	2	3	ρ	Σ	
	CG RAM (8)	'	7	G	W	g	w	7	+	3	4	g	π	
1000	CG RAM (1)	(8	H	X	h	x	4	0	*	U	7	×	
	(2))	9	I	Y	i	y	9	7	1	h	'	y	
1010	(3)	*	:	J	Z	j	z	±	3	h	h	j	¥	
	(4)	+	;	K	[k	[+	9	h	0	*	κ	
1100	(5)	,	<	L	¥	l	l	h	9	7	7	φ	κ	
	(6)	-	=	M]m)	u	z	^	0		±	÷	
1110	(7)	.	>	N	^	n	→	3	h	h	°	ñ		
	CG RAM (8)	/	?	O	_	o	←	u	y	7	"	ö		

LCD MODULE SPECIFICATION FOR APPROVAL	DATE	20/10/07
	VER.	1.0
Waveshare LCD1602	PAGE	15

15. Handling Precautions

1. Limitation of Application:
 Optrex products are designed for use in ordinary electronic devices such as business machines, telecommunications equipment, measurement devices and etc. Please handle the products with care. (see below)
 Optrex products are not designed, intended, or authorized for use in any application which the failure of the product could result in a situation where personal injury or death may occur. these applications include, but are not limited to. life-sustaining equipment, nuclear control devices, aerospace equipment, devices related to hazardous or flammable materials, etc. [If Buyer intends to purchase or use the Optrex Products for such unintended or unauthorized applications, Buyer must secure prior written consent to such use by a responsible officer of Optrex Corporation.] Should Buyer purchase or use Optrex Products for any such unintended or unauthorized application [without such consent]. Buyer shall indemnify and hold Optrex and its officers, employees, subsidiaries, affiliates and distributors harmless against all claims, costs, damages and expenses, and reasonable attorney's fees, arising out of, directly or indirectly, any claim of personal injury or death associated with such unintended or unauthorized use, even if such claim alleges that Optrex was negligent regarding the design or manufacture of the part.

2. Industrial Rights and Patents
 Optrex shall not be responsible for any infringement of industrial property rights of third parties in any country arising out of the application or use of Optrex products, except which directly concern the structure or production of such products.

No Press and Shock!

If pressure to LCD, orientation may be disturbed.
 LCD will broken by shock!

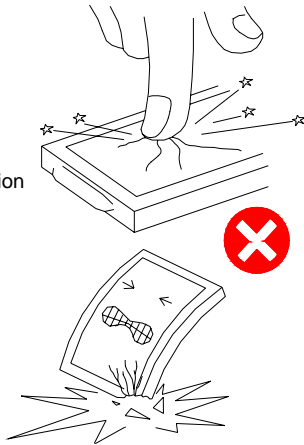

Don't Swallow or Touch Liquid Crystal!

Liquid Crystal may be leaked when display is broked.
 If it accidentally gets your hands, wash then with water!

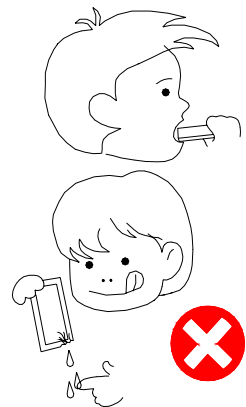

Don't not Scratch!

Polarizer is a soft material and can easily be scratched.

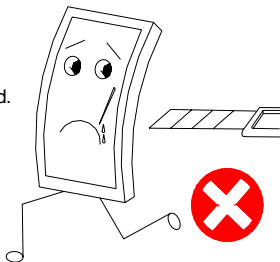

No DC Voltage to LCD!

DC volrage or driving higher than the specified voltage will reduce the lifetime of the LCD.

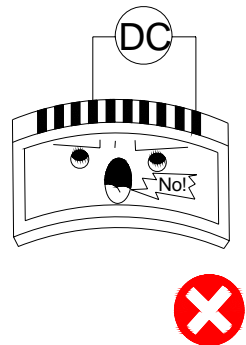

LCD MODULE SPECIFICATION FOR APPROVAL	DATE	20/10/07
	VER.	1.0
Waveshare LCD1602	PAGE	16

Don't Press the Metallic Frame and Disassemble the LCM

Pressure on the metallic frame and PCB may deform the conductive rubber or break the liquid crystal cell and back light, which will cause defects.

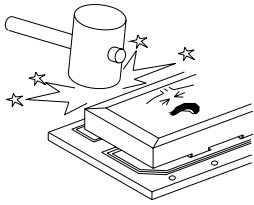

LCD may be shifted or conductive rubber may be reshaped, which will cause defects.

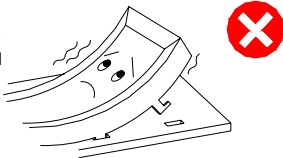

Slowly Peel Off Protective Film!

Avoid static electricity.

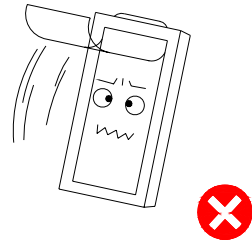

Avoid Static Electricity!

Please be sure to ground human body and electric appliances during work. It is preferable to use conductive mat on table and wear cotton clothes or conduction processed fiber. Synthetic fiber is not recommended.

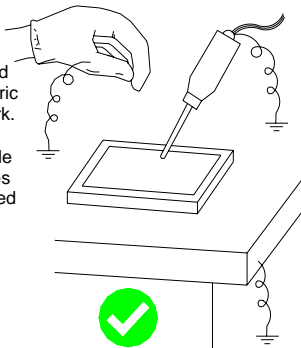

Wear Gloves While Handling!

It is preferable to wear gloves to avoid damaging the LCD.

Please do not touch electrodes with bare hands or make them dirty.

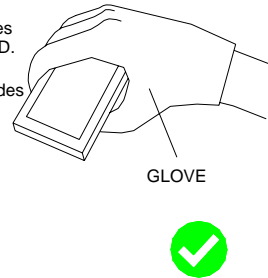

Keep Away From Extreme Heat and Humidity!

LCD deteriorates.

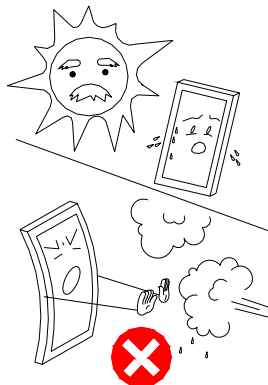

Use Alcohol to Clean Terminals!

When attaching with the heat seal or anisotropically conductive film, wipe off with alcohol before use.

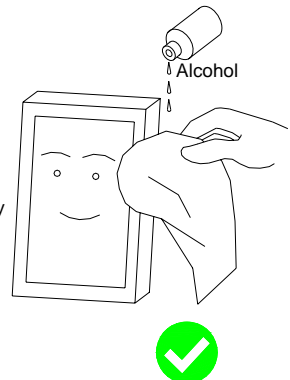

LCD MODULE SPECIFICATION FOR APPROVAL	DATE	20/10/07
	VER.	1.0
Waveshare LCD1602	PAGE	17

Don't Drop Water on LCD!

Note that the presence of waterdrops or dew in the LCD panel may deteriorate the polarizer or corrode electrode.

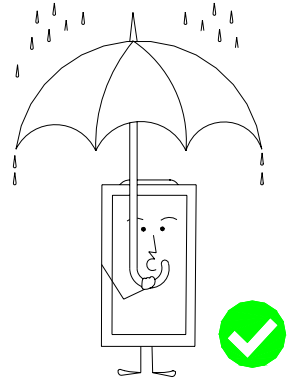

Precaution in Soldering LCD Module

Basic instructions: Solder I/O terminals only.

Use soldering iron without leakage.

(1) Soldering condition to I/O terminals

Temperature at tip of the iron: $280 \pm 10^{\circ}\text{C}$

Soldering time: 3~4 sec.

Type of solder: Eutectic solder (containing colophony-flux)

*Please do not use flux because it may soak into LCD Module or contaminate it.

*It is preferable to peel off protective film on display surface after soldering I/O terminals is finished.

(2) Remove connector or cable

*When you remove connector or cable soldered to I/O terminals, please confirm that solder is fully melted. If you remove by force, electrodes at I/O terminals may be damaged (or stripped off).

*It is recommended to use solder suction machine.

Long-term Storage

If it is necessary to store LCD modules for a long time, please comply with the following procedures.

If storage condition is not satisfactory, display (especially polarizer) may be deteriorated or soldering I/O terminals may become difficult (some oxide is generated at I/O terminals plating).

1. Store as delivered by Optrex

2. If you store as unpacked, put in anti-static bag, seal its opening and store where it is not subjected to direct sunshine nor fluorescent lamp.

3. Store at temperature 0 to $+35^{\circ}\text{C}$ and at low humidity. Please refer to our specification sheets for storage temperature range and humidity condition.

Long-term Storage

Please use power supply with built-in surge protection circuit.

LCD MODULE SPECIFICATION FOR APPROVAL	DATE	20/10/07
	VER.	1.0
Waveshare LCD1602	PAGE	18

16. EXTERNAL DIMENSION

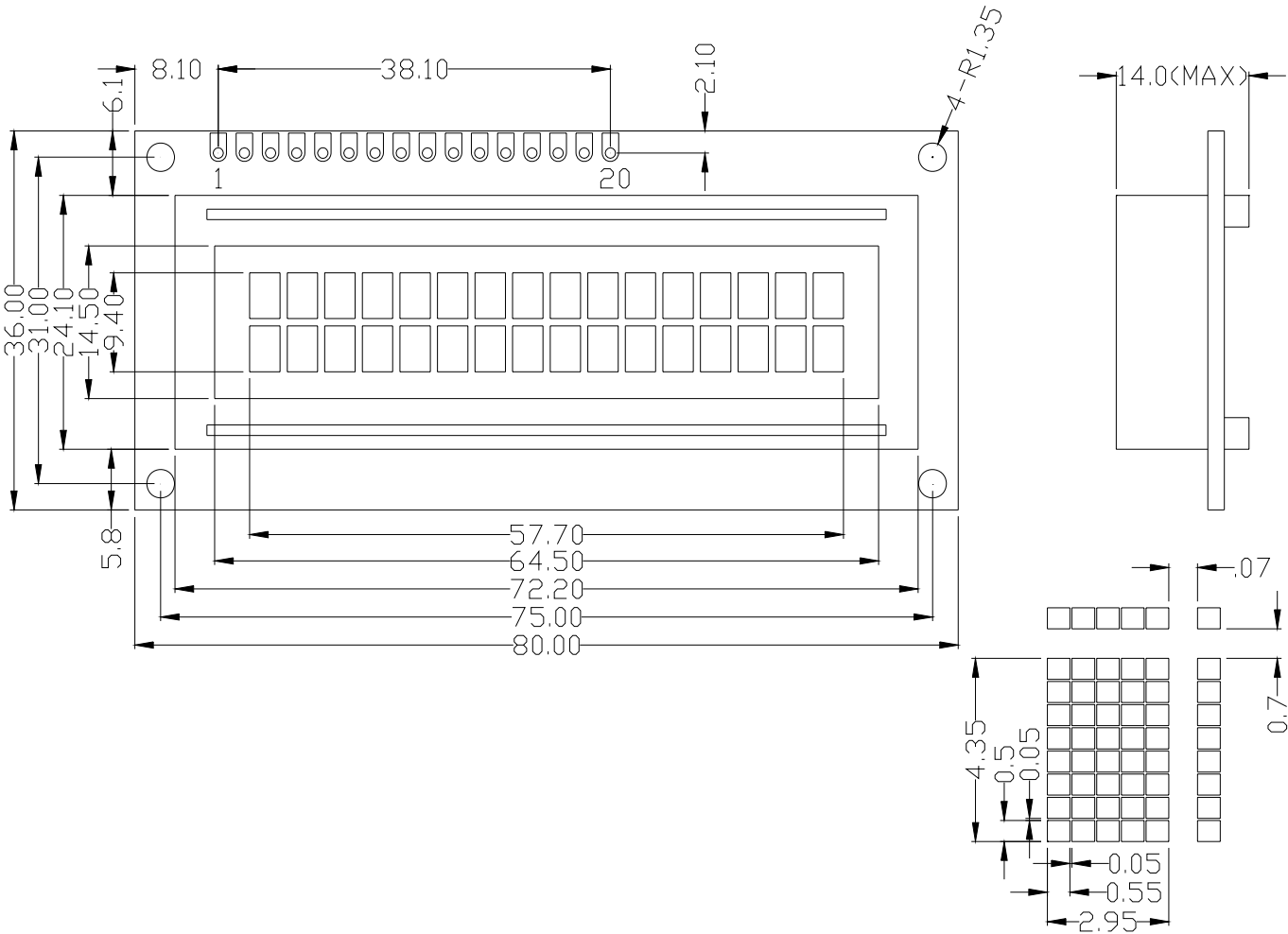

1	2	3	4	5	6	7	8
VSS	VCC	VEE	RS	R/W	E	DB0	DB1
9	10	11	12	13	14	15	16
DB2	DB3	DB4	DB5	DB6	DB7	LED+	LED-

LCD MOUDULE SPECIFICATION FOR APPROVAL	DATE	20/10/07
	VER.	1.0
Waveshare LCD1602	PAGE	19

17. INTERFACE

PIN NO.	SYMBOL	DESCRIPTION	FUNCTION
1	VSS	GROUND	0V (GND)
2	VCC	POWER SUPPLY FOR LOGIC CIRCUIT	+5V
3	VEE	LCD CONTRAST ADJUSTMENT	
4	RS	INSTRUCTION/DATA REGISTER SELECTION	RS = 0 : INSTRUCTION REGISTER RS = 1 : DATA REGISTER
5	R/W	READ/WRITE SELECTION	R/W = 0 : REGISTER WRITE R/W = 1 : REGISTER READ
6	E	ENABLE SIGNAL	
7	DB0	DATA INPUT/OUTPUT LINES	8 BIT: DB0-DB7
8	DB1		
9	DB2		
10	DB3		
11	DB4		
12	DB5		
13	DB6		
14	DB7		
15	LED+	SUPPLY VOLTAGE FOR LED+	+5V
16	LED-	SUPPLY VOLTAGE FOR LED-	0V